

IOWA FFA AGRICULTURAL MECHANICS CAREER DEVELOPMENT EVENT
WRITTEN EXAMINATION
IOWA STATE UNIVERSITY
AMES, IOWA
JUNE 7, 2007

MACHINERY and EQUIPMENT SYSTEMS
--

1. At the present time, there are _____ GPS satellites visible from where you are seated.
 - a) 1
 - b) 2
 - c) 4
 - d) 6

2. A GPS monitor is located in _____.
 - a) Boulder, Colorado
 - b) Phoenix, Arizona
 - c) Colorado Springs, Colorado
 - d) Houston Space Center, Texas

3. Real Time Kinematic (RTK) GPS systems can provide _____ accuracy.
 - a) 2 meter
 - b) 1 meter
 - c) 500 cm
 - d) Sub-inch

4. Class _____ combines, such as the 9860STS or A85 Gleaner, will be able to handle 16 row corn heads.
 - a) IV
 - b) V
 - c) VII
 - d) VIII

5. Transverse rotor combines have the rotor placed _____.
 - a) crosswise to the length of the combine
 - b) lengthwise to the combine
 - c) vertically to the combine
 - d) none of the above

6. Combine fires can be prevented by all of the following, except:
 - a) a fire extinguisher placed outside the cab door
 - b) cleaning the trash out of the engine compartment on a regular basis.
 - c) preventing oil leaks
 - d) after shutting down the combine, and stopping the engine, check all the bearings for overheating.

7. Differential GPS stationary receivers are located at _____ and _____.
 - a) Iowa City, IA and Cedar Rapids, IA
 - b) Iowa City, IA and Ames, IA
 - c) Bettendorf, IA and Davenport, IA
 - d) Ledyard, IA and Iowa City, IA

8. _____ is a common name for multi-path GPS errors.
- a) ephemeris
 - b) error correction
 - c) ghosting
 - d) double vision
9. Add-on auto-steer systems, such as the John Deere Autotrac Universal, use a _____ to steer the tractor, sprayer or combine.
- a) hydraulic motor
 - b) powered rubber wheel that contacts the steering wheel hub
 - c) computer connected to stepper motors on the axle
10. Current John Deere combines have a _____ rotor.
- a) longitudinal
 - b) transverse
 - c) diagonal
 - d) down front
11. All of the following are good safety practices to follow when operating a combine, except:
- a) always obey traffic laws when operating on the highway
 - b) run down the steps from the cab if you are in a hurry
 - c) keep flashing lights, SMV emblems and mirrors in good condition
 - d) take a break for a few minutes if you get sleepy
12. If you are following a combine, and the left flashing light is a steady light, and the right light continues to flash, it indicates:
- a) the combine operator is going to make a left turn
 - b) the left flasher has probably failed and you can ignore it
 - c) the combine operator is going to make a right turn
 - d) the combine operator is slowing down the machine

ENVIRONMENT AND NATURAL RESOURCE SYSTEMS

13. The dominant form of water erosion in agricultural areas of the United States is _____ erosion.
- a) pasture
 - b) sheet
 - c) blanket
 - d) landslide
14. Following a heavy rain, less runoff will occur in a field that is well tilled because of:
- a) finer soil textures
 - b) flatter field slopes
 - c) greater available soil moisture storage capacity
 - d) more crop cover
15. _____ is a term used to describe the level of soil acidity.
- a) "sa"
 - b) "pH"
 - c) HCl
 - d) None of the above

16. The _____ is a method used to estimate the rate of soil loss in a given area, considering several variables.
- Universal Soil Loss Equation
 - Universal Soil Erosion Formula
 - United States Soil Movement Formula
 - Universal Soil Conservation Formula
17. There should be _____ % residue coverage left on the surface of a minimum- tilled, continuous corn field.
- 0
 - 10
 - 75
 - 90
18. All of the following statements concerning Fall chisel plowing of soybean ground are true, except:
- it is not recommended in Iowa because of severe problems with soil erosion in hilly parts of the state
 - it is a good way to get a head start on next year's tillage and is a recommended practice
 - it is the cause of soil erosion, because soybeans tend to "loosen" the soil
 - it destroys the limited soil cover available from soybean residue
19. Applying manure to a field with _____ will result in the most residue left on the field to minimize runoff.
- a manure spreader then disking the field
 - a spreader then moldboard plowing
 - injecting the manure with sweep points on the injectors
 - injecting the manure with chisel points on the injectors
20. Parallel terraces can give all of the following benefits, except:
- maximum machine efficiency will be achieved
 - the work ground will tend to be more level
 - there will be more point rows
 - there will be less point rows
21. _____ is a source of nonpoint pollution of water supplies.
- sediment from croplands
 - feedlots
 - confinement milking setups
 - pesticide disposal sites
22. Land put in the Conservation Reserve Program will require:
- regular cultivation
 - growing row crops
 - regular heavy pesticide applications
 - mowing selected areas of the field, as necessary, to control noxious weeds
23. A _____ is the area on either side of a stream, planted to control runoff into the stream.
- grassy plain
 - riparian buffer
 - agricultural buffer
 - riparian plain

24. The initials NRCS stand for:
- a) National Republic Congressional Statute
 - b) National Resource Control System
 - c) Natural Resources Conservation Service
 - d) Natural Resources Continuum Society

INDUSTRY AND MARKETING SYSTEMS

25. All of the following are good safety practices when operating a small engine, except:
- a) wear tight fitting clothing which is in good condition
 - b) stay clear of hot areas on the engine
 - c) operate the engine in a well-ventilated area
 - d) wear loose-fitting jeans with frayed knees
26. If you have hit a rock with the push-type lawn mower blade, all of the following are possible outcomes, except:
- a) the engine power will increase
 - b) the crankshaft could be broken
 - c) the timing could be late and cause a loss of power
 - d) the engine crankcase could be cracked
27. OSHA requires the lawn mower blade to stop in _____ seconds if the safety bar on the handle of a push-type lawn mower is released.
- a) 28
 - b) 20
 - c) 3
 - d) 0.01
28. If a lawn mower strikes a rock, it could be propelled by the blades at speeds up to _____ MPH.
- a) 200
 - b) 100
 - c) 10
 - d) 5
29. On a diesel small engine, _____ is compressed on the compression stroke.
- a) air and gasoline
 - b) air and diesel fuel
 - c) air only
 - d) diesel fuel
30. On a diesel small engine, _____ is the ignition source.
- a) compression due to heat
 - b) a spark
 - c) heat due to compression
 - d) an auxiliary ignition source
31. The choke on a small engine:
- a) enriches the air-fuel mixture entering the combustion chamber
 - b) leans out the air-fuel mixture entering the combustion chamber
 - c) allows less fuel into the combustion chamber
 - d) allows more air to enter the combustion chamber

32. The key switch stops a small gasoline engine(equipped with a magneto) by:
- removing the power to the ignition system
 - grounding the ignition circuit
 - reversing the current flow in the ignition circuit
 - cutting off the fuel supply
33. 10% ethanol-gasoline blends can be used in:
- all recently manufactured small gasoline engines
 - only engines manufactured by Briggs and Stratton
 - any engines not manufactured in Japan
 - only engines with 18 or more horsepower
34. You can always find the recommended engine oil to use in your lawn and garden tractor by:
- looking at the engine data plate
 - looking in the parts book
 - looking in the operator's manual
 - contacting Wal-Mart only
35. All of the following statements are correct, except:
- you should follow the manufacturer's recommendations for correct oil viscosity
 - all small engines can use the same type of oil
 - 4-cycle engines do not have oil mixed in the gasoline
 - small 2-cycle engines generally do not have oil in a crankcase
36. _____ fumes can be noxious or fatal, if a small engine is operated in a confined space.
- carbon dioxide
 - oxygen
 - ozone
 - carbon monoxide

ENERGY SYSTEMS

37. If a person is being shocked by a 115 volt electrical circuit, you should first:
- administer CPR
 - phone 911
 - shut off the circuit
 - call the fire department
38. If you wanted to have a fan, used to control temperature in stored grain, turn off at temperatures at or below 40 degrees, you would use a:
- normally closed (NC) thermostatic switch that opens on temperature decrease
 - normally closed (NC) thermostatic switch that opens on temperature increase
 - humidistat
 - pressure switch
39. All of the following are requirements for components used in a grain drying and storage set-up, except:
- explosion-proof light fixtures
 - open frame motors
 - sealed explosion-proof motors
 - properly grounded electrical components

40. _____ is the instrument used to measure continuity in an electrical circuit.
- voltmeter
 - ammeter
 - potentiometer
 - ohmmeter
41. If an electrical wire is broken in a circuit, this fault is described as a(n):
- ground
 - short
 - open
 - crossover
42. A device that uses a small electrical current to control a large electrical current, is called a(n):
- relay
 - capacitor
 - transformer
 - inverter
43. If you need to fasten 4 wires together in a junction box, you would:
- fasten all 4 wires together with 1 wire nut
 - fasten 3 wires together with a pigtail, and then fasten the pigtail to the other wire with a second wire nut
 - fasten 2 wires together with a pigtail, then fasten the other 2 wires together with a pigtail and a wire nut, and then fasten the 2 pigtails together with a wire nut
 - twist all 4 wires together and cover them with a generous amount of black tape
44. If you are going to work on the electrical circuit of a grain drying setup, you should turn off the electrical circuit and:
- put a lockout device on the control box
 - work fast so that you get done before someone turns the circuit back on
 - leave the box cover open so that others will know that you are working on the circuit
 - hire an extra person to stand guard at the control box
45. _____ is the correct way to hook up the wires in an electrical circuit.
- bare to green screw, white to chrome screw, black to brass screw
 - bare to chrome screw, white to green screw, black to brass screw
 - bare to circuit enclosure, white to chrome screw, black to brass screw
 - black to brass screw, white and bare to chrome screw
46. Present electrical circuits have _____ volts.
- 110 or 240
 - 115 or 220
 - 115 or 230
 - 115 or 250
47. A GFCI is a:
- ground fault checking integrated circuit
 - ground fault circuit interrupter
 - ground finding circuit interrupter
 - none of the above

48. An aeration fan on a grain bin would be most economical to run :
- whenever it is below 12 degrees F.
 - whenever there is humidity in the air
 - as needed, when the air temperature is above freezing
 - all the time

STRUCTURAL SYSTEMS

49. Based on 1.245 cubic feet per bushel, a 30 ft. diameter grain bin, 20 ft. tall, would hold this many bushels:

- 11,305
- 45,000
- 10,220
- 22,222

Formula

$$RBC = (0.785) \times (D) \times (D) \times (H) \times (0.8)$$

where RBC = Round Bin Capacity

0.785 = a constant = $\pi/4$

D = bin diameter in feet

H = bin height in feet

0.8 = conversion factor(cu. ft. to Bu.)

50. _____ joints in a grain bin are better able to withstand extreme rapid temperature changes in an Iowa winter.

- welded
- brazed
- fusion welded
- bolted

51. The slump test determines

- flow ability of concrete, indicating water content
- the sand content of the concrete mix
- engineered form factor X
- the identification of the source of the concrete

52. _____ comes in the sack and _____ is the material placed in the form.

- concrete, cement
- readymix, cement
- cement, concrete
- sackcrete, cement

53. Hydration is the chemical process that forms:

- concrete
- cement
- readymix
- none of the above

54. 1-2-3, are the numbers to remember when mixing concrete. These numbers indicate:

- 1 part sand, 2 parts cement, 3 parts crushed limestone
- 1 part cement, 2 parts sand, 3 parts crushed limestone
- 1 part crushed limestone, 2 parts cement, 3 parts, sand
- none of the above

55. All of the following are good safety practices to use when unloading a round steel grain bin, except:

- never enter the bin when it is being unloaded
- keep children safely away from the grain bin
- only allow adults to enter the grain bin while it is being unloaded
- know the whereabouts of everyone in the area of the bin

56. A crust can be formed on top of a bin full of stored grain. All of the following are true, except:
- a) the crust can remain in place, even though the grain below the crust has been partially removed
 - b) the crust will fall in as soon as you start to remove the grain
 - c) it is absolutely unsafe to walk on the grain crust
 - d) the crust was formed due to grain and storage conditions
57. All of the following are good safety practices to use when working around grain bins, except:
- a) never enter a grain bin while it is being unloaded
 - b) if fumigants have been used in a grain bin, always allow sufficient air flow through the bin before attempting to enter the bin
 - c) attach a large knotted rope to the center top of the bin and let it hang down into the bin as a possible way for someone to grab hold in case they get caught in a grain spiral
 - d) only allow someone to enter the bin while it is being unloaded if they are properly supervised
58. Grain dust explosions are:
- a) not possible in a bin that has been grounded
 - b) an unlikely hazard that can be ignored
 - c) a hazard associated with filling a bin or removing stored grain from a bin
 - d) can only happen during the summer
59. All of the following statements are true concerning grain stored in a pile on the ground back of the local Co-op except:
- a) grain should be checked regularly for insect damage, mold and moisture content
 - b) grain is assumed to be in good condition unless you smell spoilage
 - c) grain moved or delivered before warm weather occurs
 - d) grain should be covered, if possible
60. Corn weighs _____ pounds per bushel.
- a) 30
 - b) 45
 - c) 56
 - d) 70

**2007
AGRICULTURAL MECHANICS
CAREER DEVELOPMENT EVENT
WRITTEN TEST
ANSWER KEY
IOWA STATE UNIVERSITY
AMES, IOWA
JUNE 7, 2007**

- | | | |
|-------|-------|-------|
| 1. C | 31. A | 60. C |
| 2. C | 32. B | |
| 3. D | 33. A | |
| 4. D | 34. C | |
| 5. A | 35. B | |
| 6. A | 36. D | |
| 7. D | 37. C | |
| 8. C | 38. A | |
| 9. B | | |
| 10. A | 39. B | |
| 11. B | 40. D | |
| 12. C | 41. C | |
| 13. B | 42. A | |
| 14. C | 43. C | |
| 15. B | 44. A | |
| 16. A | 45. A | |
| 17. C | 46. C | |
| 18. B | 47. B | |
| 19. D | 48. C | |
| 20. C | 49. A | |
| 21. A | 50. D | |
| 22. D | 51. A | |
| 23. B | 52. C | |
| 24. C | 53. A | |
| 25. D | 54. A | |
| 26. A | 55. C | |
| 27. C | 56. B | |
| 28. A | 57. D | |
| 29. C | 58. C | |
| 30. C | 59. B | |

State of Iowa
 DEPARTMENT OF EDUCATION
 Career Education Division
 Grimes State Office Building
 Des Moines, IA 50319

CONTESTANT NAME _____

CONTESTANT SCHOOL _____

COMPUTER APPLICATION
Grain Unloading Capacity

Use the provided Excel computer spreadsheet to assist in determining the corn grain unloading conveyor capacity for a grain center. Relevant pages from MWPS-13 (Grain Drying, Handling and Storage Handbook) are provided as reference if needed. Instructions:

1. Enter your name and school into the computer spreadsheet.
2. Enter the given data and formulas to determine the grain unloading conveyor capacity (UC).
3. Print out the completed spreadsheet.
4. Change the data for the new scenarios and answer the specified questions.
5. Staple this sheet to your printout and turn into the judge.

<p><u>Given (enter data into spreadsheet):</u></p> <ul style="list-style-type: none"> • Harvest width (W) = 15 ft • Speed (S) = 4.0 mph • Harvest efficiency (e) = 0.70 • Corn yield (Y) = 180 bu/ac • Capacity of largest vehicle (LV) = 850 bu • Capacity of smallest vehicle (SV) = 500 bu • Farthest distance – field to grain center (FD) = 1.1 miles • Average travel speed for largest vehicle when fully loaded (VL_{full}) = 20 mph. • Average travel speed for largest vehicle when empty (VL_{empty}) = 35 mph. • Miscellaneous activities (TMA) = 7 min • Actual pit capacity (PC_a) = 450 bu 	<p><u>Enter formula into spreadsheet using cell references</u></p> <ul style="list-style-type: none"> • Effective Field Capacity (EFC) = (W)(S)(e)/8.25 ac/hr • Maximum harvest rate (MHR) = (EFC)(Y) bu/hr <p><u>Spreadsheet Output (calculated by spreadsheet):</u></p> <ul style="list-style-type: none"> • Travel time from field to grain center - largest vehicle (TTG) • Travel time return to field – largest vehicle (TTR) • Time to fill smallest vehicle (Sfill) • Time available for largest vehicle to unload largest vehicle (AUT) • Unloading conveyor capacity (UC)
---	--

NEW SCENARIOS - QUESTIONS:

<p>1. What is the required unloading conveyor capacity (UC) if the distance to the farthest field increases to 2.5 miles due to a land purchase? Is this an increase or decrease?</p>	<p>UC = _____ bu/hr <input type="checkbox"/> Increase <input type="checkbox"/> Decrease</p>
<p>2. What is the required unloading conveyor capacity (UC) if the harvesting is done with an 8-row combine (W=20 ft) instead of a 6-row combine (W=15 ft)? Is this an increase or decrease?</p>	<p>UC = _____ bu/hr <input type="checkbox"/> Increase <input type="checkbox"/> Decrease</p>
<p>3. What is the required unloading conveyor capacity (UC) if vehicle loading switched from field's end (e=0.7) to on-the-go (e=0.8)? Is this an increase or decrease?</p>	<p>UC = _____ bu/hr <input type="checkbox"/> Increase <input type="checkbox"/> Decrease</p>

Evaluation Score Sheet

<u>Item</u>	<u>Points</u>	
	<u>Possible</u>	<u>Earned</u>
1. Data entered correctly.....	11	_____
2. Formulas entered correctly	6	_____
2. Computer printouts	2	_____
3. New scenario questions	6	_____
TOTAL	25	<div style="border: 1px solid black; width: 50px; height: 50px; margin: 0 auto;"></div>

State of Iowa
 DEPARTMENT OF EDUCATION
 Career Education Division
 Grimes State Office Building
 Des Moines, IA 50319

CONTESTENT NAME ANSWER KEY

CONTESTANT SCHOOL _____

COMPUTER APPLICATION
Grain Unloading Capacity

Use the provided Excel computer spreadsheet to assist in determining the corn grain unloading conveyor capacity for a grain center. Relevant pages from MWPS-13 (Grain Drying, Handling and Storage Handbook) are provided as reference if needed. Instructions:

1. Enter your name and school into the computer spreadsheet.
2. Enter the given data and formulas to determine the grain unloading conveyor capacity (UC).
3. Print out the completed spreadsheet.
4. Change the data for the new scenarios and answer the specified questions.
5. Staple this sheet to your printout and turn into the judge.

<p><u>Given (enter data into spreadsheet):</u></p> <ul style="list-style-type: none"> • Harvest width (W) = 15 ft • Speed (S) = 4.0 mph • Harvest efficiency (e) = 0.70 • Corn yield (Y) = 180 bu/ac • Capacity of largest vehicle (LV) = 850 bu • Capacity of smallest vehicle (SV) = 500 bu • Farthest distance – field to grain center (FD) = 1.1 miles • Average travel speed for largest vehicle when fully loaded (VL_{full}) = 20 mph. • Average travel speed for largest vehicle when empty (VL_{empty}) = 35 mph. • Miscellaneous activities (TMA) = 7 min • Actual pit capacity (PC_a) = 450 bu 	<p><u>Enter formula into spreadsheet using cell references</u></p> <ul style="list-style-type: none"> • Effective Field Capacity (EFC) = (W)(S)(e)/8.25 ac/hr • Maximum harvest rate (MHR) = (EFC)(Y) bu/hr <p><u>Spreadsheet Output (calculated by spreadsheet):</u></p> <ul style="list-style-type: none"> • Travel time from field to grain center - largest vehicle (TTG) • Travel time return to field – largest vehicle (TTR) • Time to fill smallest vehicle (Sfill) • Time available for largest vehicle to unload largest vehicle (AUT) • Unloading conveyor capacity (UC)
---	--

NEW SCENARIOS - QUESTIONS:

<p>1. What is the required unloading conveyor capacity (UC) if the distance to the farthest field increases to 2.5 miles due to a land purchase? Is this an increase or decrease?</p>	<p>UC = <u>1720</u> bu/hr <input checked="" type="checkbox"/> Increase <input type="checkbox"/> Decrease</p>
<p>2. What is the required unloading conveyor capacity (UC) if the harvesting is done with an 8-row combine (W=20 ft) instead of a 6-row combine (W=15 ft)? Is this an increase or decrease?</p>	<p>UC = <u>1941</u> bu/hr <input checked="" type="checkbox"/> Increase <input type="checkbox"/> Decrease</p>
<p>3. What is the required unloading conveyor capacity (UC) if vehicle loading switched from field's end (e=0.7) to on-the-go (e=0.8)? Is this an increase or decrease?</p>	<p>UC = <u>1458</u> bu/hr <input checked="" type="checkbox"/> Increase <input type="checkbox"/> Decrease</p>

Evaluation Score Sheet

<u>Item</u>	<u>Points</u>	
	<u>Possible</u>	<u>Earned</u>
1. Data entered correctly.....	11	_____
2. Formulas entered correctly	6	_____
2. Computer printouts	2	_____
3. New scenario questions	<u>6</u>	_____
TOTAL	25	<div style="border: 1px solid black; width: 50px; height: 50px; margin: 0 auto;"></div>

Name:	ANSWER KEY FOR PRINTOUT
School:	

Parameter	Symbol	Units	Value	Comment
Harvest width	W	ft	15	Enter data from instruction sheet
Average harvest speed	S	mph	4.0	Enter data from instruction sheet
Harvest efficiency	e	decimal	0.7	Enter data from instruction sheet
Effective Field Capacity	EFC	ac/hr	5.1	Enter formula in cell D10 using cell references
Corn Yield	Y	bu/ac	180	Enter data from instruction sheet
Maximum Harvest Rate	MHR	bu/hr	916.4	Enter formula in cell D12 using cell references
Largest Vehicle Capacity	LV	bu	850	Enter data from instruction sheet
Smallest Vehicle Capacity	SV	bu	500	Enter data from instruction sheet
Farthest distance - field to grain center	FD	miles	1.1	Enter data from instruction sheet
Average travel speed - largest vehicle (full)	VL _{full}	mph	20	Enter data from instruction sheet
Average travel speed - largest vehicle (empty)	VL _{empty}	mph	35	Enter data from instruction sheet
Travel time to grain center - largest vehicle	TTG	min	3.3	Calculated results
Travel time return to field - largest vehicle	TTR	min	1.9	Calculated results
Miscellaneous activity time	TMA	min	7	Enter data from instruction sheet
Time to fill the smallest vehicle	Sfill	min	32.7	Calculated results
Time available to unload largest vehicle	AUT	min	20.6	Calculated results
Pit capacity	PC _a	bu	450	Enter data from instruction sheet
Unloading capacity	UC	bu/hr	1,168	Calculated results

Color Key		Enter data from instruction sheet
		Enter formula using cell references
		Calculated results

Name:	ANSWER KEY FOR SCENARIO #1
School:	

Parameter	Symbol	Units	Value	Comment
Harvest width	W	ft	15	Enter data from instruction sheet
Average harvest speed	S	mph	4.0	Enter data from instruction sheet
Harvest efficiency	e	decimal	0.7	Enter data from instruction sheet
Effective Field Capacity	EFC	ac/hr	5.1	Enter formula in cell D10 using cell references
Corn Yield	Y	bu/ac	180	Enter data from instruction sheet
Maximum Harvest Rate	MHR	bu/hr	916.4	Enter formula in cell D12 using cell references
Largest Vehicle Capacity	LV	bu	850	Enter data from instruction sheet
Smallest Vehicle Capacity	SV	bu	500	Enter data from instruction sheet
Farthest distance - field to grain center	FD	miles	2.5	Enter data from instruction sheet
Average travel speed - largest vehicle (full)	VL _{full}	mph	20	Enter data from instruction sheet
Average travel speed - largest vehicle (empty)	VL _{empty}	mph	35	Enter data from instruction sheet
Travel time to grain center - largest vehicle	TTG	min	7.5	Calculated results
Travel time return to field - largest vehicle	TTR	min	4.3	Calculated results
Miscellaneous activity time	TMA	min	7	Enter data from instruction sheet
Time to fill the smallest vehicle	Sfill	min	32.7	Calculated results
Time available to unload largest vehicle	AUT	min	14.0	Calculated results
Pit capacity	PC _a	bu	450	Enter data from instruction sheet
Unloading capacity	UC	bu/hr	1,720	Calculated results

Color Key		Enter data from instruction sheet
		Enter formula using cell references
		Calculated results

Name:	ANSWER KEY FOR SCENARIO #2
School:	

Parameter	Symbol	Units	Value	Comment
Harvest width	W	ft	20	Enter data from instruction sheet
Average harvest speed	S	mph	4.0	Enter data from instruction sheet
Harvest efficiency	e	decimal	0.7	Enter data from instruction sheet
Effective Field Capacity	EFC	ac/hr	6.8	Enter formula in cell D10 using cell references
Corn Yield	Y	bu/ac	180	Enter data from instruction sheet
Maximum Harvest Rate	MHR	bu/hr	1221.8	Enter formula in cell D12 using cell references
Largest Vehicle Capacity	LV	bu	850	Enter data from instruction sheet
Smallest Vehicle Capacity	SV	bu	500	Enter data from instruction sheet
Farthest distance - field to grain center	FD	miles	1.1	Enter data from instruction sheet
Average travel speed - largest vehicle (full)	VL _{full}	mph	20	Enter data from instruction sheet
Average travel speed - largest vehicle (empty)	VL _{empty}	mph	35	Enter data from instruction sheet
Travel time to grain center - largest vehicle	TTG	min	3.3	Calculated results
Travel time return to field - largest vehicle	TTR	min	1.9	Calculated results
Miscellaneous activity time	TMA	min	7	Enter data from instruction sheet
Time to fill the smallest vehicle	Sfill	min	24.6	Calculated results
Time available to unload largest vehicle	AUT	min	12.4	Calculated results
Pit capacity	PC _a	bu	450	Enter data from instruction sheet
Unloading capacity	UC	bu/hr	1,941	Calculated results

Color Key		Enter data from instruction sheet
		Enter formula using cell references
		Calculated results

Name:	ANSWER KEY FOR SCENARIO #3
School:	

Parameter	Symbol	Units	Value	Comment
Harvest width	W	ft	15	Enter data from instruction sheet
Average harvest speed	S	mph	4.0	Enter data from instruction sheet
Harvest efficiency	e	decimal	0.8	Enter data from instruction sheet
Effective Field Capacity	EFC	ac/hr	5.8	Enter formula in cell D10 using cell references
Corn Yield	Y	bu/ac	180	Enter data from instruction sheet
Maximum Harvest Rate	MHR	bu/hr	1047.3	Enter formula in cell D12 using cell references
Largest Vehicle Capacity	LV	bu	850	Enter data from instruction sheet
Smallest Vehicle Capacity	SV	bu	500	Enter data from instruction sheet
Farthest distance - field to grain center	FD	miles	1.1	Enter data from instruction sheet
Average travel speed - largest vehicle (full)	VL _{full}	mph	20	Enter data from instruction sheet
Average travel speed - largest vehicle (empty)	VL _{empty}	mph	35	Enter data from instruction sheet
Travel time to grain center - largest vehicle	TTG	min	3.3	Calculated results
Travel time return to field - largest vehicle	TTR	min	1.9	Calculated results
Miscellaneous activity time	TMA	min	7	Enter data from instruction sheet
Time to fill the smallest vehicle	Sfill	min	28.6	Calculated results
Time available to unload largest vehicle	AUT	min	16.5	Calculated results
Pit capacity	PC _a	bu	450	Enter data from instruction sheet
Unloading capacity	UC	bu/hr	1,458	Calculated results

Color Key		Enter data from instruction sheet
		Enter formula using cell references
		Calculated results

State of Iowa
DEPARTMENT OF EDUCATION
Career Education Division
Grimes State Office Building
Des Moines, IA 50319

CONTESTANT NAME _____

CONTESTANT SCHOOL _____

ENERGY SYSTEMS
Wiring an Aeration Fan
Problem Solving/Skill

Instructions:

You will have 15 minutes to do this exercise. Ask for assistance if you're not sure what you are doing. A branch circuit is to be run from a service panel to a 115-volt aeration fan. Extend the branch circuit cable through a box connector clamp and connect it to the circuit breaker and neutral bus in the panel. Use proper wiring procedures and safe work habits.

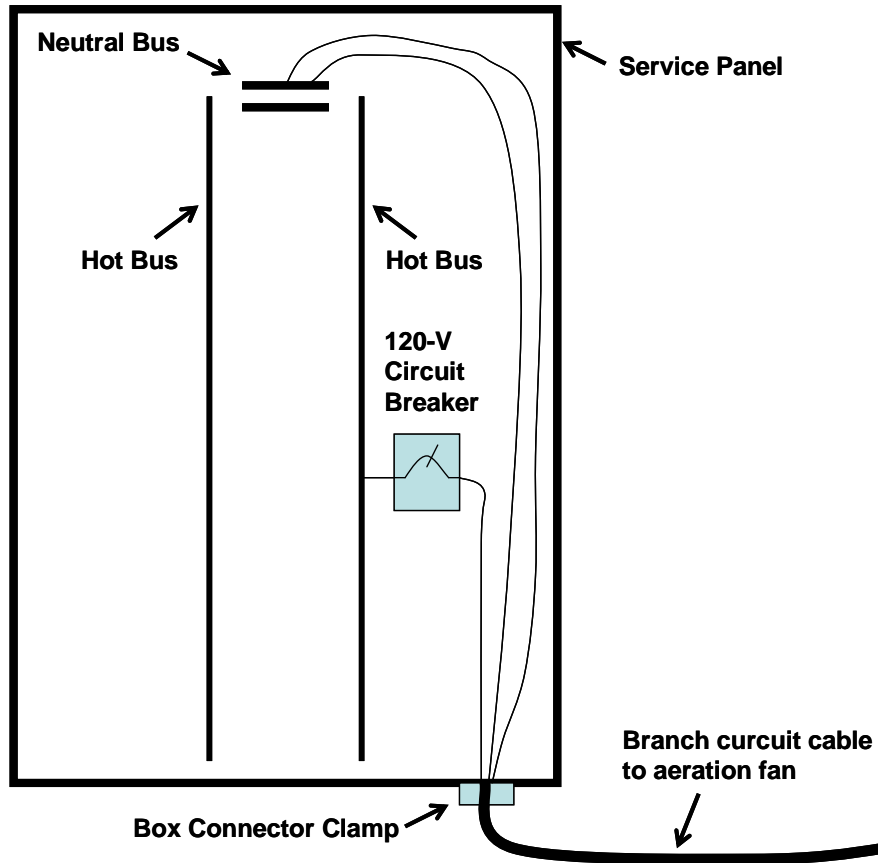

Evaluation Score Sheet

<u>Items</u>	<u>Points</u>	
	Possible	Earned
Proper circuitry, wire colors, screw colors.....	12	_____
Proper stripping of conductors and cable jackets.....	5	_____
Proper connection of conductors.....	5	_____
Safe work habits.....	3	_____

Total 25

State of Iowa
 DEPARTMENT OF EDUCATION
 Career Education Division
 Grimes State Office Building
 Des Moines, IA 50319

CONTESTANT NAME _____

CONTESTANT SCHOOL _____

Environmental and Natural Resource Systems
 Residue Management
 Individual Problem Solving/Skill

Instructions:

You will have 15 minutes to do this exercise. You will need a calculator and PM 1701A (Residue Management and Cultural Practices – Resource Conservation Practices).

Part 1: The line-transect method is a practical field method of estimating the residue cover after any field operation. Using the 50-foot tape stretched diagonally across simulated crop rows, determine the percent residue cover (show your work next to the answer box below for partial credit):

Percent residue cover =

_____ %

Part 2: Complete the table below. Calculate the residue losses from fall harvest to after planting for soybeans for each field operation/conditions in the table below using the tables from the “Residue Management & Cultural Practices” Iowa State University Extension bulletin provided. Assume “Fragile Residue” with minimum residue reduction due to seasonal, implement, or field operations.

Field Operation/ Condition	Reduction Factor (Table 2.)	X	Residue Cover Remaining After Each Operation	=	Final Residue Cover
Harvest	0.70	X	100	=	70
Winter decomposition		X		=	
Anhydrous ammonia application knifed in using coil shanks		X		=	
Planting with a drill with fluted coulter attachments		X		=	

Part 3: Conservation tillage is defined to be any tillage/planting system which leaves at least 30 percent of the field surface covered with crop residue cover after planting has been completed. This can reduce erosion by at least 50 percent compared to a bare, fallow soil situation. For the field operation/conditions above, was conservation tillage accomplished? If not, what could be done to maintain a conservation tillage status?

Evaluation Score Sheet

Items	Points	
	Possible	Earned
Part 1: Proper residue cover determination using the line-transect method.....	12	_____
Part 2: Completion of conservation tillage table.....	9	_____
Part 3: Answer to conservation tillage question.....	4	_____
..... Total	25	<table border="1" style="display: inline-table; width: 60px; height: 40px; vertical-align: middle;"></table>

State of Iowa
DEPARTMENT OF EDUCATION
Career Education Division
Grimes State Office Building
Des Moines, IA 50319

CONTESTANT NAME _____

CONTESTANT SCHOOL _____

ENRS SKILL
Residue Management
Individual Problem Solving/Skill

Instructions:

You will have 15 minutes to do this exercise. You will need a calculator.

Part 1: The line-transect method is a practical field method of estimating the residue cover after any field operation. Using the 50-foot tape stretched diagonally across simulated crop rows, determine the percent residue cover (show your work next to the answer box below for partial credit):

Percent residue cover = 40 ± 4 % (20 foot markings landing on residue X 2 (double for 50' tape) = 40%)

Part 2: Complete the table below. Calculate the residue losses from fall harvest to after planting for soybeans for each field operation/conditions in the table below using the tables from the "Residue Management & Cultural Practices" Iowa State University Extension bulletin provided. Assume "Fragile Residue" (**therefore use second column of values for percent breakdown**) with minimum residue reduction due to seasonal, implement, or field operations (**therefore use maximum value within the range given**).

Field Operation/ Condition	Reduction Factor (Table 2.)	X	Residue Cover Remaining After Each Operation	=	Final Residue Cover
Harvest	0.70	X	100	=	70
Winter decomposition	1.00	X	70	=	70
Anhydrous ammonia application knifed in using coil shanks	0.65	X	70	=	45.5
Planting with a drill with fluted coulter attachments	0.70	X	45.5	=	31.8

Part 3: Conservation tillage is defined to be any tillage/planting system which leaves at least 30 percent of the field surface covered with crop residue cover after planting has been completed. This can reduce erosion by at least 50 percent compared to a bare, fallow soil situation. For the field operation/conditions above, was conservation tillage accomplished? If not, what could be done to maintain a conservation tillage status?

Yes. If more residue cover was desired, using coil shanks with coulters for the anhydrous ammonia application would change the final residue cover 49% (0.70 x 70%). Or the planting operation could also be changed to a drill with smooth coulters or ripple coulters (0.85 x 45.5% = 38.6%) to meet the minimum conservation tillage level of 30%. A combination of these two operations would result in even greater residue cover (0.70 x 70% = 49%, then 0.85 x 49% = 41.6%). Other operations could also be considered.

Evaluation Score Sheet

Items	Points	
	Possible	Earned
Part 1: Proper residue cover determination using the line-transect method.....	12	_____
Part 2: Completion of conservation tillage table.....	9	_____
Part 3: Answer to conservation tillage question.....	4	_____

Total 25

State of Iowa
 DEPARTMENT OF EDUCATION
 Career Education Division
 Grimes State Office Building
 Des Moines, IA 50319

CONTESTENT NAME _____

CONTESTANT SCHOOL _____

INDUSTRY AND MARKETING SYSTEMS

Problem Solving/Skill
 Small Gasoline Engines

You are doing repair on a small gasoline engine that has been treated roughly. It is a Briggs and Stratton model series 133400 Type 0359 – 5 hp, single-cylinder. (An example of this engine is at the front of the room.)

In the repair process, you make the following measurement: Crankpin journal = 0.952 inches

Does the crankshaft need to be replaced? (check one): Yes No

You also notice that these items need to be replaced:

- magneto armature
- spark plug (you'll order two)
- air filter cartridge (you'll order two)
- engine gaskets
- carburetor gaskets

Using the Illustrated Parts List and Price sheet, determine the cost of the parts necessary to repair this engine. Complete the following table

Item	Part Number	Unit Cost (\$)	No. ordered	Price
Magneto armature				
Spark plug				
Air filter				
Engine gasket set				
Carburetor gasket set				
Crankshaft (<i>may not be needed</i>)				
Subtotal				
Tax (7%)				
Shipping		\$5.25 for orders under \$20 \$8.70 for orders between \$50 and \$100 \$12.50 for orders between \$100 and \$200		
Total				

Evaluation Score Sheet

<u>Items</u>	<u>Points</u>	
	<u>Possible</u>	<u>Earned</u>
1. Crankshaft replacement.....	5	_____
2. Part numbers	6	_____
2. Price and amount.....	6	_____
3. Tax	2	_____
4. Shipping	2	_____
5. Total	3	_____
5. Attitude and use of materials	1	_____
..... Total	25	<div style="border: 1px solid black; width: 40px; height: 40px; margin: 0 auto;"></div>

State of Iowa
 DEPARTMENT OF EDUCATION
 Career Education Division
 Grimes State Office Building
 Des Moines, IA 50319

CONTESTENT NAME **KEY**

INDUSTRY AND MARKETING SYSTEMS

Problem Solving/Skill
 Small Gasoline Engines

You are doing repair on a small gasoline engine that has been treated roughly. It is a Briggs and Stratton model series 133400 Type 0359 – 7.5 hp, single-cylinder. (An example of this engine is at the front of the room.)

In the repair process, you make the following measurement: Crankpin journal = 0.952 inches

Does the crankshaft need to be replaced? (check one): Yes No

You also notice that these items need to be replaced:

- magneto armature
- spark plug (you'll order two)
- air filter cartridge (you'll order two)
- engine gaskets
- carburetor gaskets

Using the Illustrated Parts List and Price sheet, determine the cost of the parts necessary to repair this engine. Complete the following table

Item	Part Number	Unit Cost (\$)	No. ordered	Price
Magneto armature	397358	\$38.25	1	\$38.25
Spark plug	802592	\$2.40	2	\$4.80
Air filter cartridge	494511	\$4.85	2	\$9.70
Engine gasket set	495661	\$11.25	1	\$11.25
Carburetor gasket set	498261	\$3.85	1	\$3.85
Crankshaft (<i>may not be needed</i>)	495645	\$66.20	1	\$66.20
Subtotal				\$134.05
Tax (7%)				\$9.38
Shipping	\$5.25 for orders under \$50 \$8.70 for orders between \$50 and \$100 \$12.50 for orders between \$100 and \$200			\$12.50
Total				\$143.43

Evaluation Score Sheet

<u>Items</u>	<u>Points</u>	
	<u>Possible</u>	<u>Earned</u>
1. Crankshaft replacement.....	5	_____
2. Part numbers	6	_____
2. Price and amount.....	6	_____
3. Tax	2	_____
4. Shipping	2	_____
5. Total	3	_____
5. Attitude and use of materials	1	_____
..... Total	25	_____

State of Iowa
 DEPARTMENT OF EDUCATION
 Career Education Division
 Grimes State Office Building
 Des Moines, IA 50319

CONTESTENT NAME

KEY

INDUSTRY AND MARKETING SYSTEMS

Problem Solving/Skill
 Small Gasoline Engines

You are doing repair on a small gasoline engine that has been treated roughly. It is a Briggs and Stratton model series 133400 Type 0359 – 7.5 hp, single-cylinder. (An example of this engine is at the front of the room.)

In the repair process, you make the following measurement: Crankpin journal = 0.952 inches

Does the crankshaft need to be replaced? (check one): Yes No

You also notice that these items need to be replaced:

- magneto armature
- spark plug (you'll order two)
- air filter cartridge (you'll order two)
- engine gaskets
- carburetor gaskets

Using the Illustrated Parts List and Price sheet, determine the cost of the parts necessary to repair this engine. Complete the following table

Item	Part Number	Unit Cost (\$)	No. ordered	Price
Magneto armature	397358	\$38.25	1	\$38.25
Spark plug	802592	\$2.40	2	\$4.80
Air filter cartridge	494511	\$4.85	2	\$9.70
Engine gasket set	495661	\$11.25	1	\$11.25
Carburetor gasket set	498261	\$3.85	1	\$3.85
Crankshaft (<i>may not be needed</i>)	495645	\$66.20	1	\$66.20
	499764	\$7.55		
Subtotal				\$134.05
Tax (7%)				\$9.38
Shipping	\$5.25 for orders under \$50 \$8.70 for orders between \$50 and \$100 \$12.50 for orders between \$100 and \$200			\$12.50
Total				\$155.93

Evaluation Score Sheet

<u>Items</u>	<u>Points</u>	
	<u>Possible</u>	<u>Earned</u>
1. Crankshaft replacement.....	5	_____
2. Part numbers	6	_____
2. Price and amount.....	6	_____
3. Tax	2	_____
4. Shipping	2	_____
5. Total	3	_____
5. Attitude and use of materials	1	_____
..... Total	25	_____

Iowa FFA Agricultural Mechanics Career Development Event - 2007

State of Iowa Department of Education
 Career Education Division
 Grimes State Office Building
 Des Moines, IA 50319

CONTESTANT NAME _____

CONTESTANT SCHOOL _____

MACHINERY AND EQUIPMENT SYSTEMS
 Combine and GPS Problem Solving/Skill

Instructions:

You have 15 minutes to do this exercise. Using the sections from the owner's manual at your station, and your knowledge of combines, answer the following questions.

I. What are the last 3 digits of the Product (Combine) Identification Number _____ 1 pt.

II. Identify by proper name the machine components and their function. 8 pts.

Name	Function
a) _____	_____
b) _____	_____
c) _____	_____
d) _____	_____

III. Determine the initial crop settings (standard cylinder) for corn and soybeans: 6 pts.

	<u>Corn (dry, firm cob)</u>	<u>Soybeans</u>
Cylinder Speed (RPM)	_____	_____
Concave Indicator settings	_____	_____
Fan speed (RPM)	_____	_____

IV. What openings are the chaffer, sieve, and extension indicators adjusted to (mm)? **(DO NOT ADJUST)** 4 pts.

Chaffer	_____ mm	Extension	_____ mm
Sieve	_____ mm		
Are these settings properly adjusted for corn? (circle answer) Yes No			

V. Where are these components of the yield monitoring system located on the combine? 3 pts.

<u>Component</u>	<u>Location</u>
GPS receiver	_____
Yield sensor	_____
User interface	_____

VI. Name two components of the yield monitoring system that should be calibrated prior to harvest. 2 pts.

1. _____ 2. _____

Evaluation Score Sheet

<u>Items</u>	<u>Points</u>	
	<u>Possible</u>	<u>Earned</u>
PIN.....	1	_____
Part Identification/Function	8	_____
Initial Crop Settings	6	_____
Chaffer Sieve Adjustment.....	4	_____
Yield monitor components.....	3	_____
Yield monitor calibration	2	_____
Safety	1	_____
Total	25	_____

State of Iowa
 DEPARTMENT OF EDUCATION
 Career Education Division
 Grimes State Office Building
 Des Moines, IA 50319

CONTESTENT NAME _____

CONTESTANT SCHOOL _____

STRUCTURAL SYSTEMS
 Problem Solving/Skills
 Grain Storage Structure Construction

Your task is to compute the amount of concrete needed for construction of a 27-foot diameter grain bin. The structure is pictured on the back of this sheet. Complete the following calculations to solve this problem.

1. Grain bin floor:

- a. Diameter of floor _____ ft. Radius of floor _____ ft. (1 pts.)
- d. Cubic feet of floor _____ cu.ft. (3 pts.)
- c. Cubic yards of concrete for floor _____ cu.yds. (Round up to nearest 0.5 cu.yds.) (2 pts.)

2. Grain bin foundation:

- a. Cross-section size of foundation _____ inches by _____ inches (1 pts.)
- b. Cubic feet of foundation _____ cu.ft. (3 pts.)
- c. Cubic yards of concrete for foundation _____ cu.yds. (Round up to nearest 0.5 cu.yds.) (2 pts.)

3. Grain bin footing:

- a. Cross-section size of footing _____ inches by _____ inches (1 pts.)
- b. Cubic feet of footing _____ cu.ft. (3 pts.)
- c. Cubic yards of concrete for footing _____ cu.yds. (Round up to nearest 0.5 cu.yds.) (2 pts.)

4. Total cubic yards of concrete for grain bin floor, foundation and footings _____ cu.yds. (2 pts.)

5. Total cost of concrete at \$90.00 per cu.yd.: _____ dollars (round up to the nearest \$) (3 pts.)

Evaluation Score Sheet

	<u>Items</u>	<u>Points</u>	
		<u>Possible</u>	<u>Earned</u>
1.	Grain bin floor.....	6	_____
2.	Grain bin foundation.....	6	_____
2.	Grain bin footing.....	6	_____
3.	Total cubic yards of concrete.....	2	_____
4.	Total cost of concrete.....	3	_____
5.	Attitude and use of materials.....	2	_____
 Total	25	<div style="border: 1px solid black; width: 40px; height: 40px; margin: 0 auto;"></div>

Side View

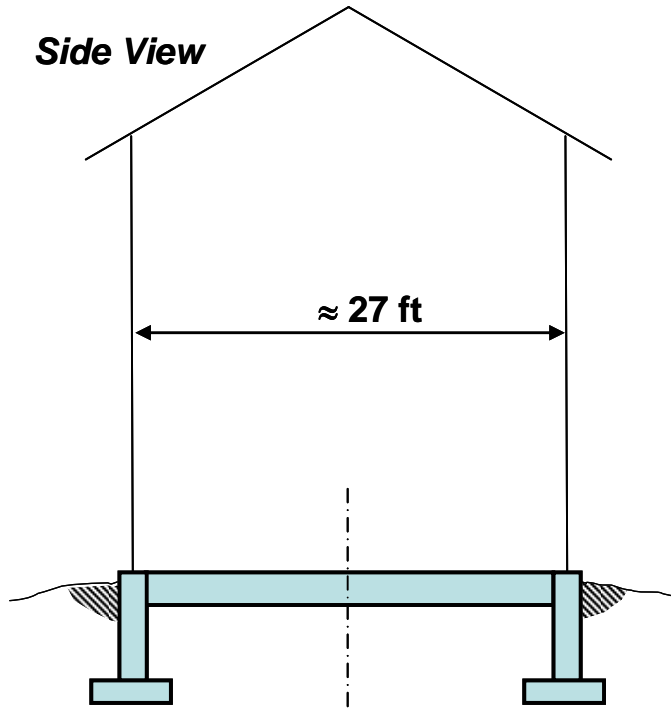

Detail of concrete floor and foundation/footings

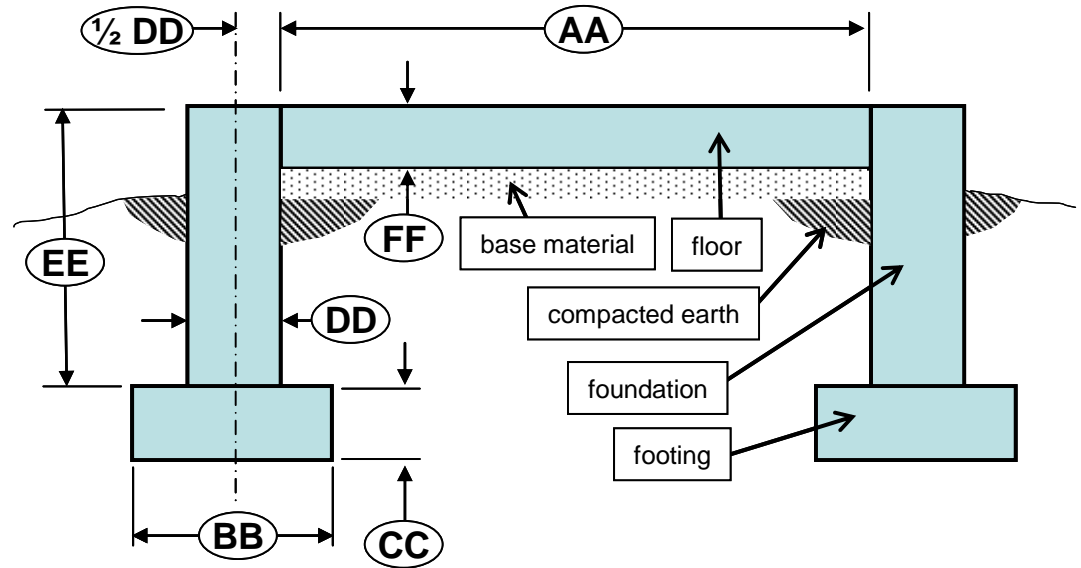

Top View of Concrete

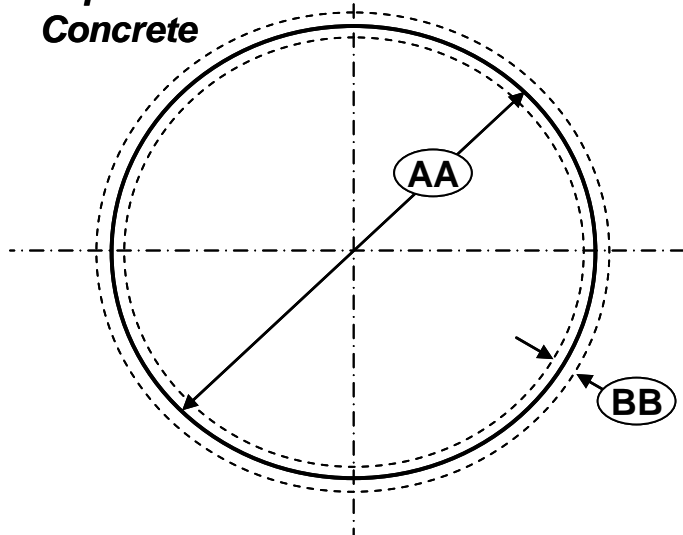

AA = 26.5 ft DD = 15 inches
 BB = 24 inches EE = 42 inches
 CC = 12 inches FF = 6 inches

Formulas

Circle Area = $(\pi) \times (R^2) = (0.785) \times (D^2)$
 Disk Volume = $(\pi) \times (R^2) \times (\text{thickness}) = (0.785) \times (D^2) \times (\text{thickness})$
 Circumference = $(\pi) \times (D) = (3.14) \times (D)$
 Volume of a ring = $(\text{midpoint circumference}) \times (\text{thickness})$
 D = diameter
 R = radius

Drawing not to scale

State of Iowa
 DEPARTMENT OF EDUCATION
 Career Education Division
 Grimes State Office Building
 Des Moines, IA 50319

CONTESTENT NAME ANSWER KEY

CONTESTANT SCHOOL _____

STRUCTURAL SYSTEMS
 Problem Solving/Skills
 Grain Storage Structure Construction

Your task is to compute the amount of concrete needed for construction of a 27-foot diameter grain bin. The structure is pictured on the back of this sheet. Complete the following calculations to solve this problem.

1. Grain bin floor:

- a. Diameter of floor 26.5 ft. Radius of floor 13.25 ft. (1 pts.)
- d. Cubic feet of floor 275.8 cu.ft. (3 pts.)
- c. Cubic yards of concrete for floor 10.5 cu.yds. (Round up to nearest 0.5 cu.yds.) (2 pts.)

2. Grain bin foundation:

- a. Cross-section size of foundation 42 inches by 15 inches (1 pts.)
- b. Cubic feet of foundation 381.4 cu.ft. (3 pts.)
- c. Cubic yards of concrete for foundation 14.5 cu.yds. (Round up to nearest 0.5 cu.yds.) (2 pts.)

3. Grain bin footing:

- a. Cross-section size of footing 24 inches by 12 inches (1 pts.)
- b. Cubic feet of footing 174.6 cu.ft. (3 pts.)
- c. Cubic yards of concrete for footing 6.5 cu.yds. (Round up to nearest 0.5 cu.yds.) (2 pts.)

4. Total cubic yards of concrete for grain bin floor, foundation and footings 31.5 cu.yds. (2 pts.)

5. Total cost of concrete at \$90.00 per cu.yd.: \$2835 dollars (round up to the nearest \$) (3 pts.)

Evaluation Score Sheet

	<u>Items</u>	<u>Points</u>	
		<u>Possible</u>	<u>Earned</u>
1.	Grain bin floor.....	6	_____
2.	Grain bin foundation.....	6	_____
2.	Grain bin footing.....	6	_____
3.	Total cubic yards of concrete.....	2	_____
4.	Total cost of concrete.....	3	_____
5.	Attitude and use of materials.....	<u>2</u>	_____
 Total	25	_____

Side View

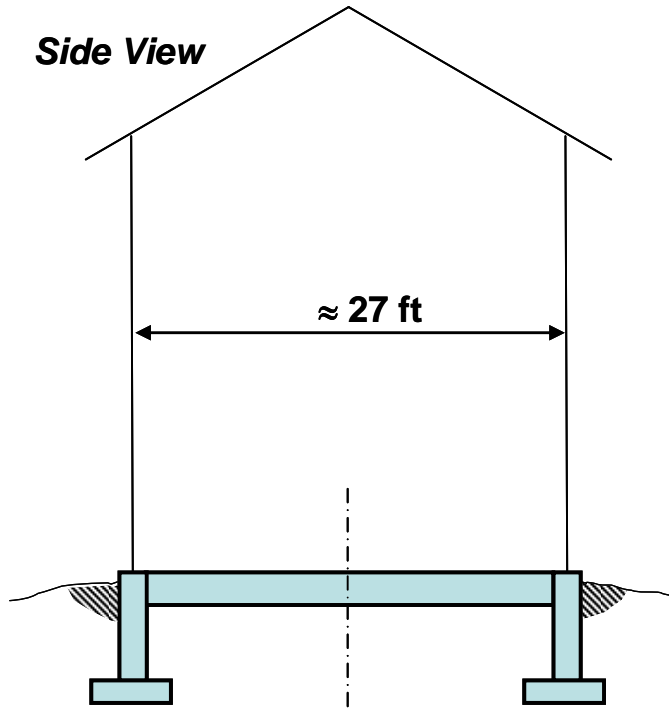

Detail of concrete floor and foundation/footings

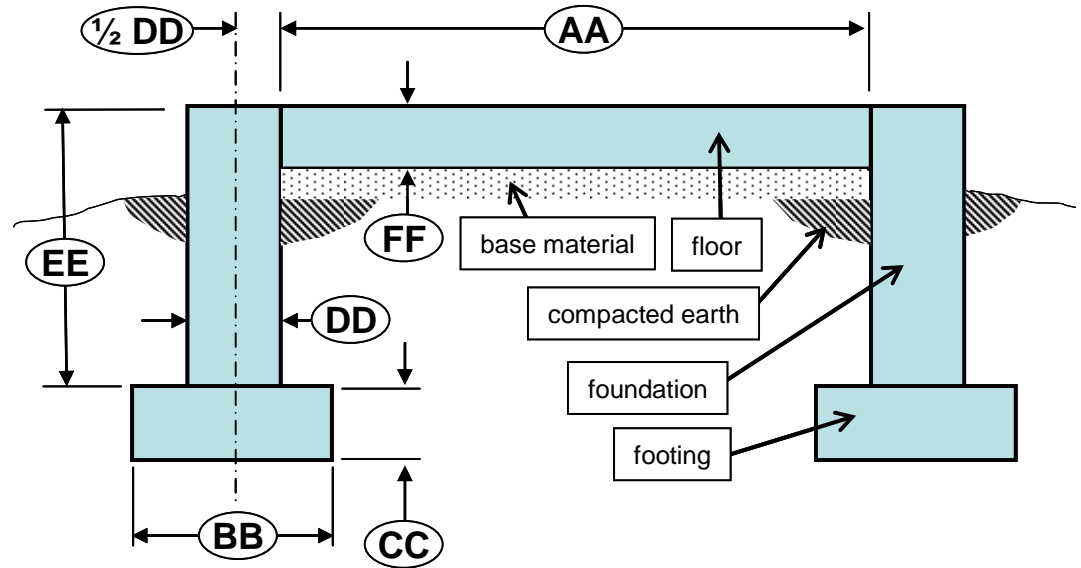

Top View of Concrete

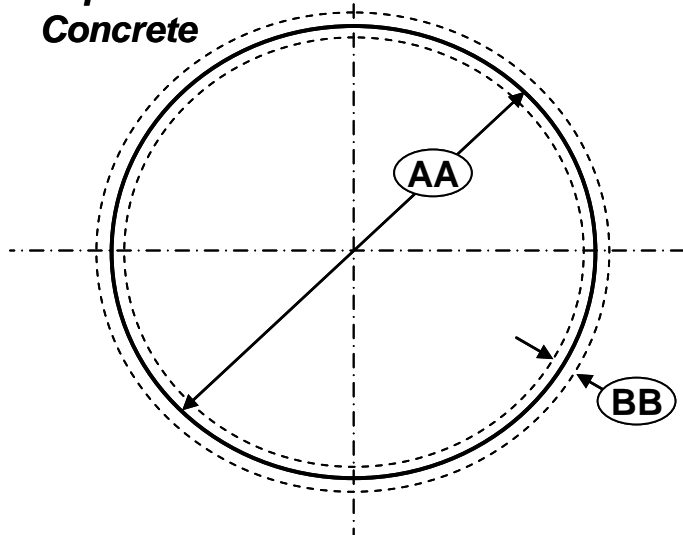

AA = 26.5 ft **DD = 15 inches**
BB = 24 inches **EE = 42 inches**
CC = 12 inches **FF = 6 inches**

Formulas

Circle Area = $(\pi) \times (R^2) = (0.785) \times (D^2)$
 Disk Volume = $(\pi) \times (R^2) \times (\text{thickness}) = (0.785) \times (D^2) \times (\text{thickness})$
 Circumference = $(\pi) \times (D) = (3.14) \times (D)$
 Volume of a ring = $(\text{midpoint circumference}) \times (\text{thickness})$
 D = diameter
 R = radius

Drawing not to scale

State of Iowa
DEPARTMENT OF EDUCATION
Career Education Division
Grimes State Office Building
Des Moines, IA 50319

CONTESTANT NAME _____

CONTESTANT SCHOOL _____

ENRS SKILL
Residue Management
Individual Problem Solving/Skill

Instructions:

You will have 15 minutes to do this exercise. You will need a calculator.

Part 1: The line-transect method is a practical field method of estimating the residue cover after any field operation. Using the 50-foot tape stretched diagonally across simulated crop rows, determine the percent residue cover (show your work next to the answer box below for partial credit):

Percent residue cover = 40 ± 4 % (20 foot markings landing on residue X 2 (double for 50' tape) = 40%)

Part 2: Complete the table below. Calculate the residue losses from fall harvest to after planting for soybeans for each field operation/conditions in the table below using the tables from the “Residue Management & Cultural Practices” Iowa State University Extension bulletin provided. Assume “Fragile Residue” (**therefore use second column of values for percent breakdown**) with minimum residue reduction due to seasonal, implement, or field operations (**therefore use maximum value within the range given**).

Field Operation/ Condition	Reduction Factor (Table 2.)	X	Residue Cover Remaining After Each Operation	=	Final Residue Cover
Harvest	0.70	X	100	=	70
Winter decomposition	1.00	X	70	=	70
Anhydrous ammonia application knifed in using coil shanks	0.65	X	70	=	45.5
Planting with a drill with fluted coulter attachments	0.70	X	45.5	=	31.8

Part 3: Conservation tillage is defined to be any tillage/planting system which leaves at least 30 percent of the field surface covered with crop residue cover after planting has been completed. This can reduce erosion by at least 50 percent compared to a bare, fallow soil situation. For the field operation/conditions above, was conservation tillage accomplished? If not, what could be done to maintain a conservation tillage status?

Yes. If more residue cover was desired, using coil shanks with coulters for the anhydrous ammonia application would change the final residue cover 49% (0.70 x 70%). Or the planting operation could also be changed to a drill with smooth coulters or ripple coulters (0.85 x 45.5% = 38.6%) to meet the minimum conservation tillage level of 30%. A combination of these two operations would result in even greater residue cover (0.70 x 70% = 49%, then 0.85 x 49% = 41.6%). Other operations could also be considered.

Evaluation Score Sheet

Items	Points	
	Possible	Earned
Part 1: Proper residue cover determination using the line-transect method.....	12	_____
Part 2: Completion of conservation tillage table.....	9	_____
Part 3: Answer to conservation tillage question.....	4	_____

Total 25